

# Electric Pump HYDRAULIC PE17 SERIES

**Up to 55 Ton**  
279 cm<sup>3</sup>/min.  
2 Speed

For maintenance and construction applications.

- For use with single-acting or double-acting cylinders at operating pressures to 700 bar.
- For intermittent duty; starts under full load.
- Equipped with 0,37Kw (½ hp), 3,450 rpm, single-phase, thermal protected induction motor; 3 m remote control cord (PE172S has 7,6 m cord)
- Low amperage draw; small generators and low amperage circuits can be used as power source.
- Extremely quiet noise level (67-81 dBA).



PE172



PE172SM



PE174

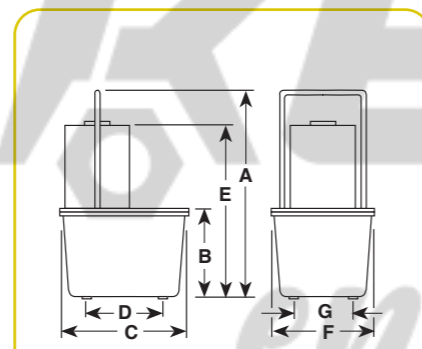
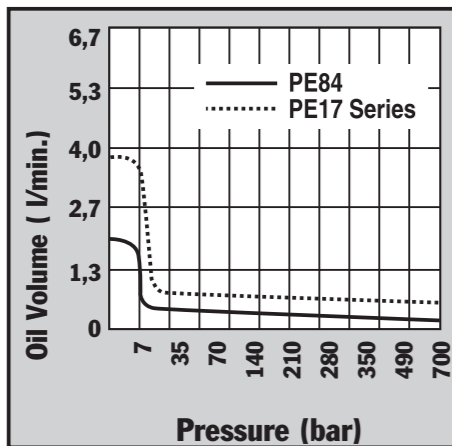

Pump No.	Max. Pressure Output		dBA at Idle and 700 bar	Amp Draw 220 V -		Oil Del. (liters./min. @) †				Dimensions (mm)							Prod. Wt. with Oil (kg)
	bar	rpm		at 700 bar	at 700 bar	0 bar	7 bar	350 bar	700 bar	A	B	C	D	E	F	G	
PE17 Series	700	2850	67/81*	5	3,9	2,5	0,3	0,2	470	178	289	181	378	235	130	20,4	
PE17M Series	700	2850	67/81*	5	3,9	2,5	0,3	0,2	460	168	292	—	368	241	—	24,0	

\* Measured at 0,9 m distance, all sides.

† Typical delivery. Actual flow will vary with field conditions.

Description	Order No.	Valve Type	Valve No.	Valve Function	Control Switch ††	Motor	Reservoir Usable (l)
Base model pump with 0,37 KW pump with 7,6 l thermoplastic reservoir.	PE172-50-220	2-Way	9517	Advance Return (Auto+)	Remote Motor Control (3,1m) on/off	0,37 kW, 220 V* 50/60 Hz, Single Phase	4,72
PE172-50-220, except has 9,5 l aluminum reservoir.	PE172M-50-220	2-Way	9517	Advance Return (Auto+)	Remote Motor Control (3,1m) on/off	0,37 kW, 220 V* 50/60 Hz, Single Phase	6
PE172-50-220, except has solenoid operated valve.	PE172S-50-220	3-Way	9570	Advance Hold Return	Remote Motor & Valve (7,6 m)	0,37 kW, 220 V* 50/60 Hz, Single Phase	4,72
PE172S-50-220, except has aluminum reservoir.	PE172SM-50-220	3-Way	9570	Advance Hold Return	Remote Motor & Valve (7,6 m)	0,37 kW, 220 V* 50/60 Hz, Single Phase	6
Best suited for crimping, punching, pressing. Not for lifting. Thermoplastic reservoir.	PE172A-50-2208	Auto./Dump Manifold	45554	Advance Return	Remote Motor Control (3,1 m) on/off	0,37 kW, 220 V* 50/60 Hz, Single Phase	4,72
PE172A, except has aluminum reservoir.	PE172AM-50-2208	Auto./Dump Manifold	45554	Advance Return	Remote Motor Control (3,1 m) on/off	0,37 kW, 220 V* 50/60 Hz, Single Phase	6
0,37 KW pump with 7,6 l thermoplastic reservoir. Meets CE requirements.	PE172-E220	2-Way	9517	Advance Return (Auto+)	Remote Motor Control (3,1 m) on/off	0,37 kW, 220 V* 50/60 Hz, Single Phase	4,72
PE172-50-220, except has 9,5l aluminium reservoir. Meets CE requirements	PE172M-E220	2-Way	9517	Advance Return (Auto+)	Remote Motor Control (3,1 m) on/off	0,37 kW, 220 V* 50/60 Hz, Single Phase	6
PE172-50-220, except has solenoid operated valve. Meets CE requirements	PE172S-E220	3-Way	9570	Advance Hold Return	Remote Motor & Valve (3,1m)	0,37 kW, 220 V* 50/60 Hz, Single Phase	4,72
PE172S-50-220 except has aluminium reservoir. Meets CE requirement	PE172SM-E220	3-Way	9570	Advance Hold Return	Remote Motor & Valve (3,1m)	0,37 kW, 220 V* 50/60 Hz, Single Phase	6
Best suited for crimping, punching, pressing. Thermoplastic res. Meets CE requirement	PE172A-∞	Auto./Dump Manifold	45554	Advance/Return	Remote Motor Control (3,1 m) on/off	0,37 kW, 220 V* 50/60 Hz, Single Phase	4,72
PE172A, except has aluminium reservoir. Meets CE requirements	PE172AM-∞	Auto./Dump Manifold	45554	Advance/Return	Remote Motor Control (3,1 m) on/off	0,37 kW, 220 V* 50/60 Hz, Single Phase	6
PE172-50-220, except has 9500 double-acting valve.	PE174-50-220	4-Way	9500	Advance Hold Return**	Remote Motor Control (3,1 m) on/off	0,37 kW, 220 V* 50/60 Hz, Single Phase	4,72
Same as PE174-50-220, except has aluminum reservoir.	PE174M-50-220	4-Way	9500	Advance Hold Return**	Remote Motor Control (3,1 m) on/off	0,37 kW, 220 V* 50/60 Hz, Single Phase	6
PE172-50-220, except has 9500 double-acting Valve. Meets CE requirements	PE174-E220	4-Way	9500	Advance Hold Return**	Remote Motor Control (3,1 m) on/off	0,37 kW, 220 V* 50/60 Hz, Single Phase	4,72
Same as PE174-50-220, except has aluminium Reservoir. Meets CE requirements	PE174M-E220	4-Way	9500	Advance Hold Return	Remote Motor Control (3,1 m) on/off	0,37 kW, 220 V* 50/60 Hz, Single Phase	6

\* Available with 115V., 60 Hz motor (to order , remove suffix "50-220" behind pump order number).

\*\* "Advance" position holds pressure with motor shut off.

† "Advance" position holds pressure with motor shut off. "Return" position advances cylinder with motor running and returns cylinder with motor shut off.

†† Control switch on PE17 series wired with line voltage.

∞ Not to be used for lifting.

NOTE: The remote motor control switch on 220V., 50 cycle PE17 series pumps is 24 volt (non CE).

NOTE: Usable oil is calculated with the oil fill at the recommended maximum level of 38 mm below reservoir cover plate.

‡ Some Power Team pumps are available in special configurations not listed in this catalog. Power Team can "Assemble to Order" pumps with special seals, voltages, valves, relief valve settings, etc. For your special requirements please consult your local distributor or the Power Team factory.

Also available in CE | E 110

