

Model Shown:
SPE5513DS

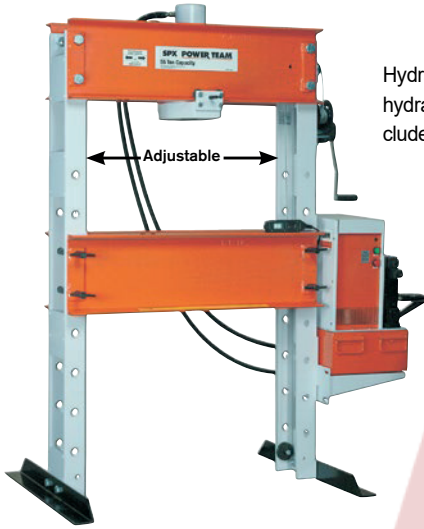

Hydraulic gauge and hydraulic fittings are included with presses.

Adjustable

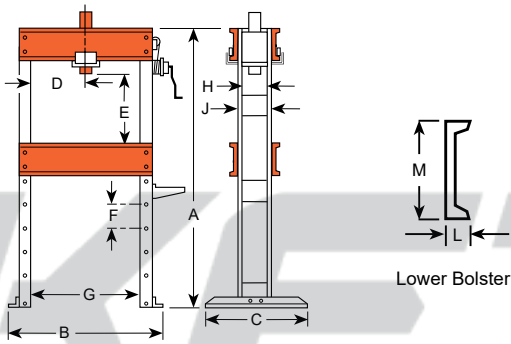

Lower Bolster

Shop Equip.

Technical Dimensions

A	B	C	D*	E	F	G	H	J	L	M	Floor Space
(in.)	(in.)	(in.)	(in.)	(in.)	(in.)	(in.)	(in.)	(in.)	(in.)	(in.)	(in.)
72.00	48.50	36.00	3.25 - 32.75	6 - 42	6.00	36.00	6.75	8.00	3.00	12.00	48.5 x 36

* Lateral head movement

Ordering Information

Order No.	Cap. (tons)	Type Cyl. Used	Stroke (in.)	Cyl. Model	Speed ††† Advance Pressing		Type of Pump	Valve Type	Pump ‡ Model	Prod. Wt. (lbs.)
					(in. / min)	(in. / min.)				
SPA556	55	Single-Acting	6.25	C556C	4.5	0.5	Air	2-Way Foot	PA6	804.00
SPM556	55	Single-Acting	6.25	C556C	0.23 (in./stroke)	0.015 (in./stroke)	Hand	Load Release	P159	814.00
SPM5513	55	Single-Acting	13.25	C5513C	0.665 (in./stroke)	0.26 (in./stroke)	Elec.	2-Way	P460	960.00
SPE556	55	Single-Acting	6.25	C556C	21.7	1.5	Elec.	2-Way ††	PE172	836.00
SPE556	55	Single-Acting	13.25	C5513C	21.7	1.5	Elec.	2-Way ††	PE172	980.00
SPE5513	55	Single-Acting	13.25	C5513C	24.4	1.9	Elec.	3-Way †	PE213S	1,056.00
SPE5513D	55	Double-Acting	13.25	RD5513	21.7	1.5	Elec.	4-Way	PE174	993.00
SPE5513DS	55	Double-Acting	13.25	RD5513	66.1	5.4	Elec.	4-Way †	PQ604S	1,114.00

† Solenoid valve with 24VAC remote control hand switch.

†† Holds pressure with motor shut-off. Also has an automatic dump setting. Furnished with a 10' remote motor control.

††† Typical performance based on 100 psi and 10,000 psi pump specifications. Actual speeds may vary with operating conditions.

‡ Pump standard with press. Other Power Team pumps can be substituted. dBA at idle and 10,000 psi: PE172—67/81; PE21 Series—70; PQ60—74/76; measured at 3 foot distance, all sides.

Note: Frame is shipped assembled.

>Features

H-FRAME SHOP PRESS

- Full off-center pressing at full rated capacity across width of upper frame without buckling or bending.
- Maximum "daylight" is 42" x 36", making positioning of even bulky work pieces easy.
- Height of press bed is easily adjusted with winch. Friction brake prevents bed from dropping and handle from spinning upon release.
- Presses with single-acting cylinders offer choice of 2-speed hand operated, electric/hydraulic, or air/hydraulic pump. Models with double-acting cylinders have an electric/hydraulic pump.
- Press models equipped with remote control enable operator to view work from all sides with fingertip control of cylinder piston travel.
- Press can be used horizontally for special applications with user-supplied support legs.



Pump Electrical Specifications

Pump Series	Description
PE17 *	1/2 hp, 115VAC, 60 cycle, single-phase.
PE21 *	1 hp, 115VAC, 60 cycle, single-phase.
PQ60 *	2 hp, 230VAC, 60 cycle, single-phase.

* Pumps available in 230VAC, 50 cycle, add suffix "-220" to order no.



Straightening Fixtures



No. SF50 – Straightening fixtures for use with 55-ton shop or 80-ton Roll-Bed® presses (2 ea).. Wt., 104 lbs.

Not part of press, order separately.