

Kombine Cırcır Sıkma

Dar alanlarda pratik çözüm



ÖNERİLEN AKSESUARLAR



Balanser

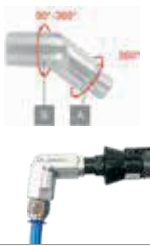

360° Bağımsız Döner Dirsek

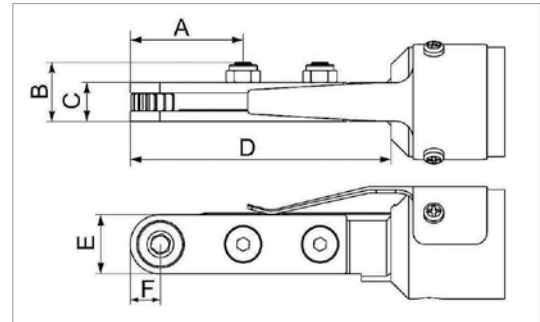

MODEL	A (mm)	B (mm)	C (mm)	D (mm)	E (mm)	F (mm)
HC - 5512	38,2	20	13,2	88,2	20	10,2
HC - 5514	44,4	26	18	109	25,2	12,2
HC - 5519	51	26	18	115	33,2	16,6
HC - 5530	66,2	26	18	129,5	48	24

MODEL	MAX. TORK	DEVİR	HAVA BASINCI	HAVA GİRİŞİ	HORTUM ÇAPİ	AĞIRLIK	UZUNLUK	FİYAT
HC - 5512	10 Nm	180 rpm	6,3 bar	1/4"	10 mm	1,30 kg	300 mm	-
HC - 5514	25 Nm	250 rpm	6,3 bar	1/4"	10 mm	1,80 kg	340 mm	-
HC - 5519	90 Nm	150 rpm	6,3 bar	1/4"	12 mm	2,42 kg	560 mm	-
HC - 5530	90 Nm	130 rpm	6,3 bar	1/4"	12 mm	2,48 kg	598 mm	-