

Hidro Pnömatik Tork Kontrollü Sıkıcılar

Yüksek Tork - Yüksek Devir

Shut-Off

Ayarlanan Torkta Durma



3/8"

- APIS - 40P
- APIS - 50P
- APIS - 60P
- APIS - 70P



1/2"

- APIS - 90P
- APIS - 100P
- APIS - 130P



3/4"

- APIS - 150P
- APIS - 180P
- APIS - 200P

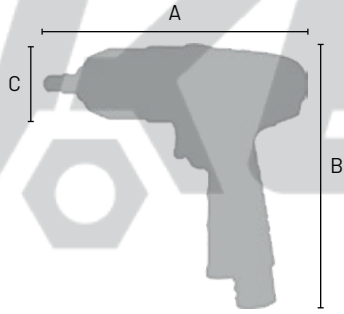

MODEL	A (mm)	B (mm)	C (mm)
APIS - 40P	147	168	46
APIS - 50P	147	168	46
APIS - 60P	158	168	46
APIS - 70P	194	192	54
APIS - 90P	200	192	54
APIS - 100P	209	195	59
APIS - 130P	216	204	64
APIS - 150P	239	215	72
APIS - 180P	263	232	78
APIS - 200P	250	239	80

ÖNERİLEN AKSESUARLAR



MODEL	MAX. TORK	DEVİR	HAVA BASINCI	HAVA GİRİŞİ	HORTUM ÇAPI	AĞIRLIK	FİYAT
APIS - 40P	10 - 19 Nm	4.600 rpm	6,3 bar	1/4"	10 mm	0,74 kg	-
APIS - 50P	13 - 27 Nm	7.200 rpm	6,3 bar	1/4"	10 mm	0,90 kg	-
APIS - 60P	20 - 35 Nm	6.200 rpm	6,3 bar	1/4"	10 mm	0,97 kg	-
APIS - 70P	32,- 55 Nm	7.200 rpm	6,3 bar	1/4"	12 mm	1,33 kg	-
APIS - 90P	57 - 90 Nm	5.400 rpm	6,3 bar	1/4"	12 mm	1,53 kg	-
APIS - 100P	75 - 120 Nm	5.300 rpm	6,3 bar	1/4"	12 mm	1,85 kg	-
APIS - 130P	113 - 148 Nm	3.600 rpm	6,3 bar	1/4"	12 mm	2,26 kg	-
APIS - 150P	145 - 210 Nm	3.700 rpm	6,3 bar	1/4"	16 mm	3,10 kg	-
APIS - 180P	180 - 255 Nm	2.700 rpm	6,3 bar	1/4"	16 mm	3,90 kg	-
APIS - 200P	230 - 450 Nm	3.000 rpm	6,3 bar	1/4"	16 mm	4,25 kg	-